

# R-6100 Rooftop Air Conditioners

## INSTALLATION INSTRUCTIONS

### MODEL R-6100 ROOFTOP AIR CONDITIONER INSTALLATION INSTRUCTIONS

#### NOTE:

1. Please read instructions all the way through before, beginning work.
2. Check that all items called out on the RD-2-1299-0 accessory kit list have been included.
3. A compressor, compressor bracket, bells and refrigerant are required to complete the installation. These items may be obtained from your RED DOT Distributor
4. The compressor must have sufficient capacity to allow the unit to deliver the rated BTU output, A compressor displacing 8 cubic Inches per revolution (Sanden SD-508 or equiv.) may be used if it can be turned 2,000 rpm or faster. A 10 cubic inch compressor (Tecumseh GH 1000, Sanden SD-10 , or equiv.) must turn faster than 1,750 rpm.

#### B. Mounting The Unit On Cab Roof

1. Remove the headliner or loosen enough to drop the center portion. (Disregard if no headliner).
2. Determine the most suitable location for mounting the air conditioning unit.
  - a. Mark the front-to-rear centerline of the cab on the outside of the cab roof.
  - b. Place the mounting template on the roof using the centerline as a guide.
  - c. Consider position of horns and marker lights.
  - d. Ensure that air flow to the unit is not obstructed.
  - e. Do not mount the unit with the front lower than the rear, as this will prohibit wafer drainage.
  - f. Avoid cutting roof stiffeners if possible. If stiffeners are cut or roof is weakened due to the cutout, reinforcement may be required.
  - g. A Mounting Channel Kit No. RD-2-1302-0 is available if it is necessary to reduce the bolt spacing width. The minimum recommended spacing width is 14 inches to ensure proper support. The channels bolt directly to the unit and either one large or two tapered rubber spacers are used to space the unit away from the roof. See Figures 1 and 2.
3. Tape the template to the roof at the desired location. Mark the mounting hole location and the roof cut-out area (punch or scribe the roof).
4. Cut the roof where marked and drill the mounting holes 1/2". Remove burrs and sharp edges,
5. Temporarily install the headliner and trace the cut-out onto it from the roof. Remove the head liner and cut out the area marked. Use caution and do not cut headliner opening larger than roof opening (check against template if in doubt).
6. Should roof reinforcing be required, fabricate and install at this time.
7. Clean the outside roof area around the cut-out and mounting holes using a mild solvent.
8. Apply a thin film of adhesive 1 "wide around upper surface of roof cutout and mounting holes. Apply sealer to the face of the sealing ring on the unit, See Figure 1. Make sure that the drain tube is located within the sealing ring. A wire or string may be wrapped around sealing ring to keep it in place if necessary.
9. Set unit on cab. Make sure that drain tube is not pinched and roof brace is installed, if required.
10. Select spacers as required to level and support unit. See Figure 2.
11. Apply adhesive to the faces of all spacers and locate over mounting holes.
12. Tighten the four cap screws provided evenly until the spacers take the load and just

Red Dot Corporation P.O. Box 88790, Seattle, WA 98138 (425) 251-6897 Fax (425) 251-3934

- begin to "bulge" slightly. Do not overtighten. Bottom of unit and roof may distaff and cause water leakage.
- Remove cover and install (4) 3/8 - 16 nuts on mounting cap screws to prevent them from backing out. Apply sealant around bolt threads and nutplates to prevent water leakage into cab.

**ROOFTOP AIR CONDITIONER INSTALLATION SCHEMATIC**  
**CHECK INSTALLATION KIT TO MAKE CERTAIN THAT ALL PARTS LISTED ARE INCLUDED**

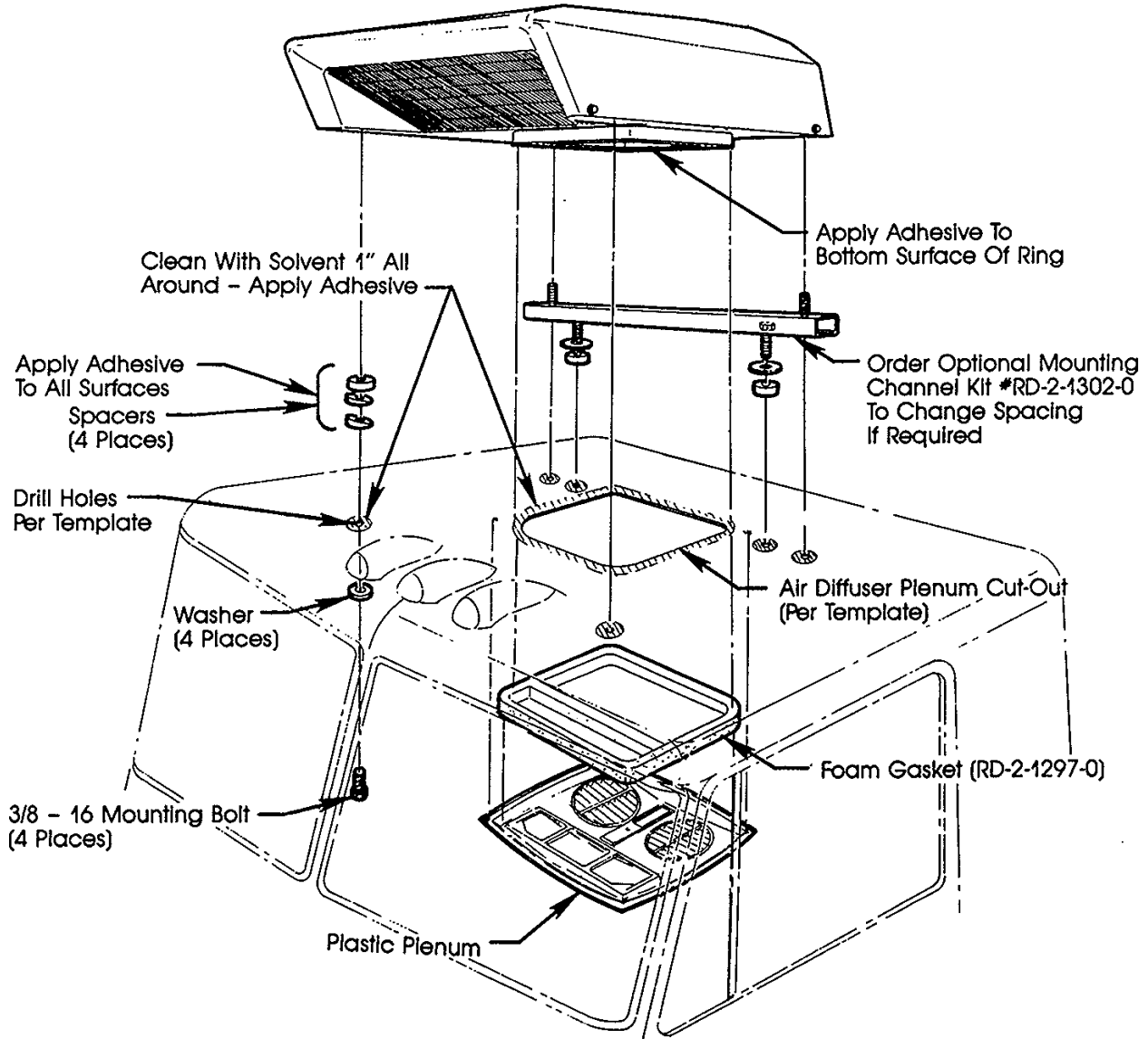

**FIGURE 1**

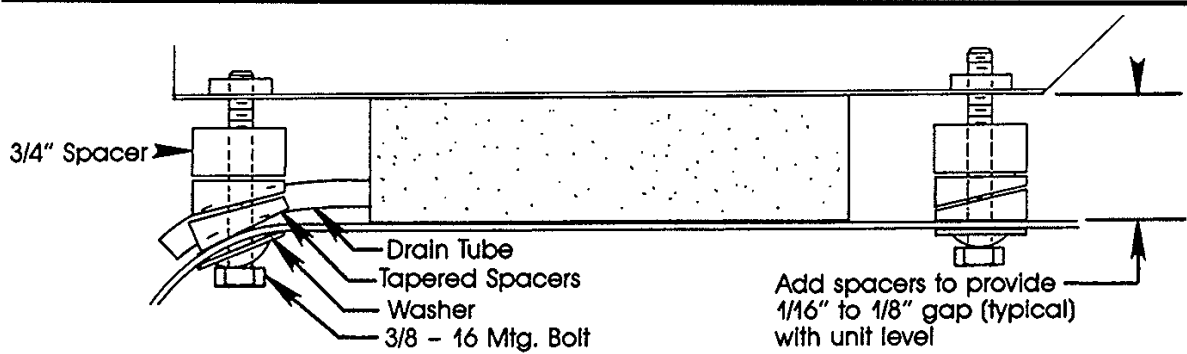

**BEFORE TIGHTENING**

**FIGURE 2**

Red Bull Corporation P.O. Box 60700, Seattle, WA 98160 (720) 201-0001 FAX (720) 201-0007

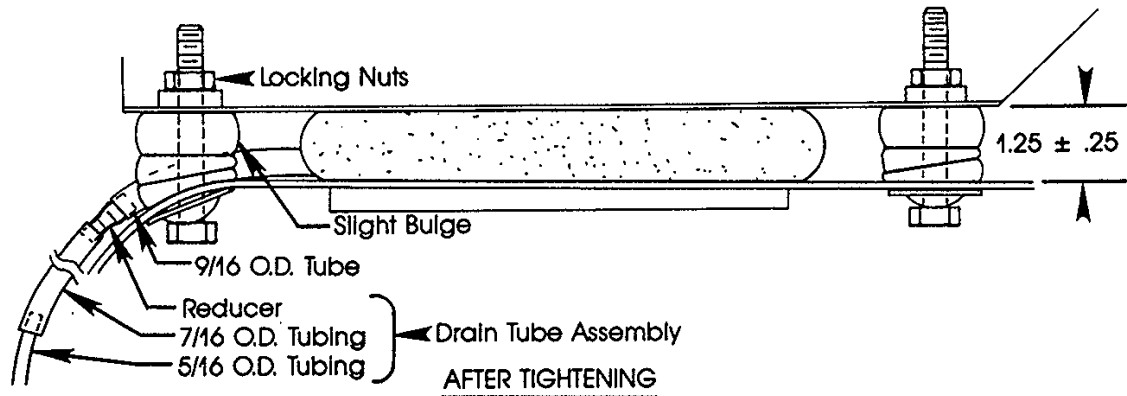
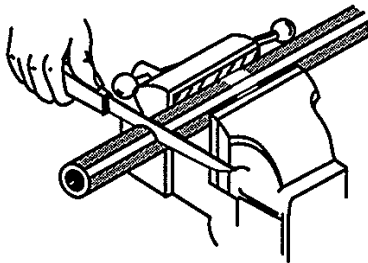

FIGURE 2

## REFRIGERANT HOSE INSTALLATION

MAKE CERTAIN "O" RINGS ARE ON ALL REFRIGERANT FITTINGS BEFORE SECURING



1. Cut refrigerant hose cleanly at 90° to proper length using a sharp clean edge.

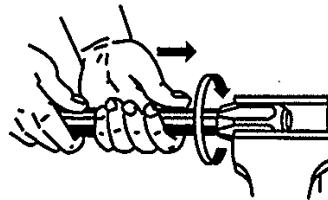

2. Screw hose into collar (left hand thread) until hose bottoms. Back out 1/4 turn.



3. Screw fitting into collar until insert bottoms. (Lubricate insert and I.D. of hose for ease of assembly.)

### REFUSABLE FITTINGS - Figure 3

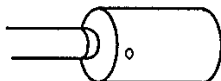

Bubble Crimp Fitting

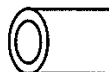

Refrigerant Hose



Crimped Fitting and Refrigerant Hose

1. Cut hose as above in Fig. 1. Lubricate the inside of the fitting ferrule with refrigerant oil. (It's important to form a seal.)

2. Insert the hose into the ferrule, being certain to fully seat the hose so it is visible in the ferrule viewing hole.

3. Use hand crimper part #79R 1510 or hydraulic crimper part #79R 1515 to crimp fitting on hose.

### BUBBLE CRIMP - Figure 4

#### C. Refrigerant Hose Installation

1. Install fittings on hose as shown in Figure 3 or Figure 4. #12 suction line recommended in place of # 10 for increased cooling capacity Use step-up fitting. Be sure to clean out refrigerant hose with clean, dry air after cuffing.
2. Install "O" Rings and connect hoses to fittings on unit (cover must be removed).
3. Clamp hoses within unit using clamps provided. Cut off end of mounting cap screw if it interferes with hose.
4. Route hoses over the top of cab and down the back wall to the compressor. On tilt cab vehicles, route hose to the cab pivot point and then to compressor.
5. Use clamps provided to secure hoses and prevent hose movement. Hoses must not come in contact with hot vehicle components, exhaust manifolds, etc., and they should not be subjected to mechanical abrasions.

#### D. Drain Hose Installation

**Note:** The drain hose is stepped down in size at two places to promote siphoning water from the drain pan under evaporator. The reduction in diameter forces the water to flow in a solid column. This creates a suction that draws the rest of the water out of the pan. For this effect to work properly, the last two feet of 5/16 O.D. drain tube should point straight down or as close to this as possible.

1. Locate small end of drain tube (5/16 O.D.) so that it exits at desired location. Make sure that it points downhill and secure With clamps or tie wraps. Do not crush the tube or cut off the 5/16 O.D. tubing.
2. Route the drain tube to the unit so that it travels in a downward direction from the unit.
3. Cut off the 7/16 O.D. tube to length and connect to reducer fitting on drain hose from unit. Secure drain tubes with tie wraps. Attach to refrigerant hoses if they run downhill properly.
4. Inspect to make sure that drain tubes are not kinked, especially at back of cab and at drain pan within plenum.

#### E. Wiring

**Note:**

- a. Unit is wired for negative ground. For positive ground systems, reverse both motor leads on condenser motor and evaporator motor.
  - b. Electrical schematic and parts breakdown can be found on evaporator plenum cover.
1. Disconnect battery.
  2. Connect the wire harness assembly to the terminal within the air plenum and route protective loom through 3/4" slot in plenum ring.
  3. Route wire harness across inside of roof and down center or side post of windshield to lower dash area.
  4. Black Wire: Connect to suitable ground.
  5. Red Wire: Connect to an ignition switch supply through a 30 amp circuit breaker (15amp/24V).
  6. White Wire: Connect to compressor clutch. Route the wire around the pivot point before connecting to compressor clutch on tilt-cab trucks.

#### F. Air Diffuser Plenum

1. Install headliner. Make sure that wire loom exits plenum ring properly and is not pinched.
2. Install (4) 10 - 32 x 3" screws in the plenum assembly and secure with retainers provided.
3. Place one foam gasket in plastic plenum assembly. If headliner is over 1 inch thick, glue two foam gaskets together. An extra foam gasket may be ordered (Part #RD-2-1297-0) if required.
4. Place the plenum assembly up to the unit and start one 10 - 32 x 3" screw.
5. Attach the switch-thermostat panel to the plenum with two 10 - 32 x 1/2" screws.
6. Tighten the four plenum assembly screws evenly until the plenum fits snugly against headliner. Make sure that gasket does not shift out of place and electrical connectors remain attached.

#### G. Final Assembly And Check

1. Install cover. Check condenser fan for adequate blade clearance.
2. Evacuate the system, test for leaks and charge with R-12 or R-134a. The unit requires 4 to 6 pounds of R-12 depending on hose length or 3 to 5 pounds of R4 34a.
3. Connect the battery.
4. Turn the ignition switch to the "on" position, turn the thermostat to the coldest point and the fan switch to "high".
  - a. The clutch should click on and be engaged. If not, see Step 9.
  - b. The condenser fan and evaporator blower should be turning at high speed.
5. Turn the fan switch to medium and low positions and check that the evaporator blower slows down.
6. Turn the thermostat off and clutch should disengage.
7. Start engine and run at 1500-2000 rpm. Turn unit on "full cold", "high fan" Check sight glass on receiver-drier for bubbles. Add 6 to 8 ounces more R-12 after the sight glass just clears.

**NOTE:** Be aware that the sight glass may appear "milky" when charging with R-134a. Be careful not to over charge the system.
8. Check thermostat to be sure clutch cycles on and off.
9. 9. If clutch does not engage the system may not have been charged to high enough pressure to actuate the Trinary switch. Place a jumper wire across terminals #1 and #2 in the switch and run system until it is fully charged then remove jumper wire.

## ELECTRICAL SCHEMATIC

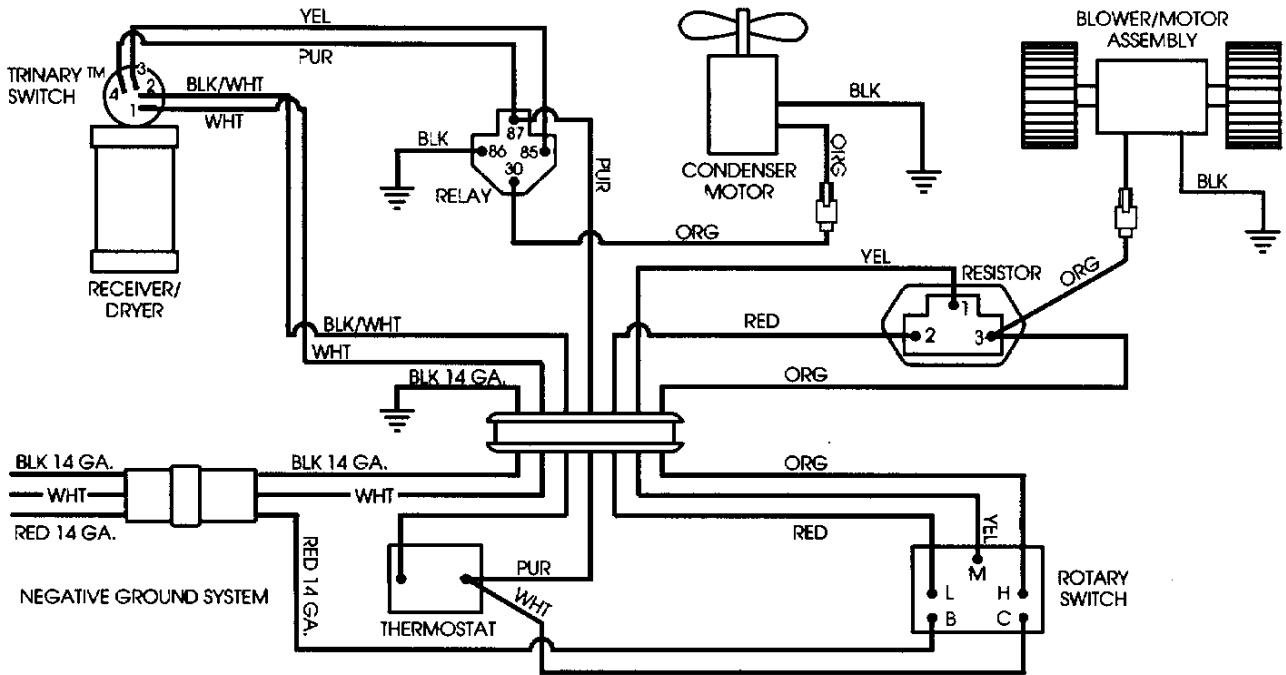

- 1) ALL WIRE IS 16GA. UNLESS OTHERWISE NOTED.
- 2) SEE RD-2-1255-0 AND RD-2-1250-0 WIRE HARNESS ASSYS FOR INDIVIDUAL WIRE DESCRIPTION AND SPECIFICATIONS.

**\*NOTE: #12 SUCTION LINE RECOMMENDED FOR INCREASED EFFICIENCY**

## PLUMBING SCHEMATIC

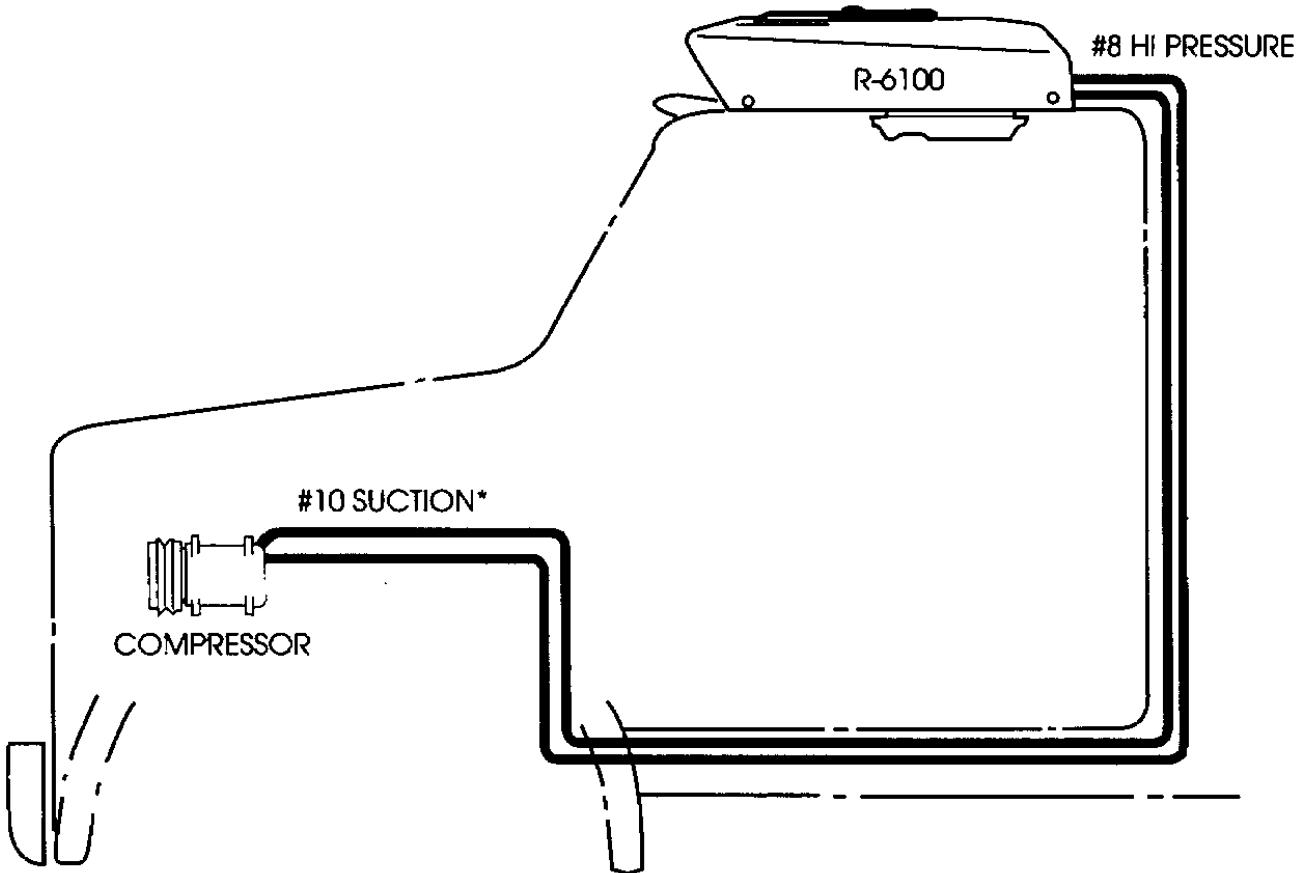

**WARNING: UNIT WARRANTY VOID IF FUSED POWER SOURCE NOT USED**