

# RD-4-7850-0P 77R1642 SKIRT MOUNT CONDENSER

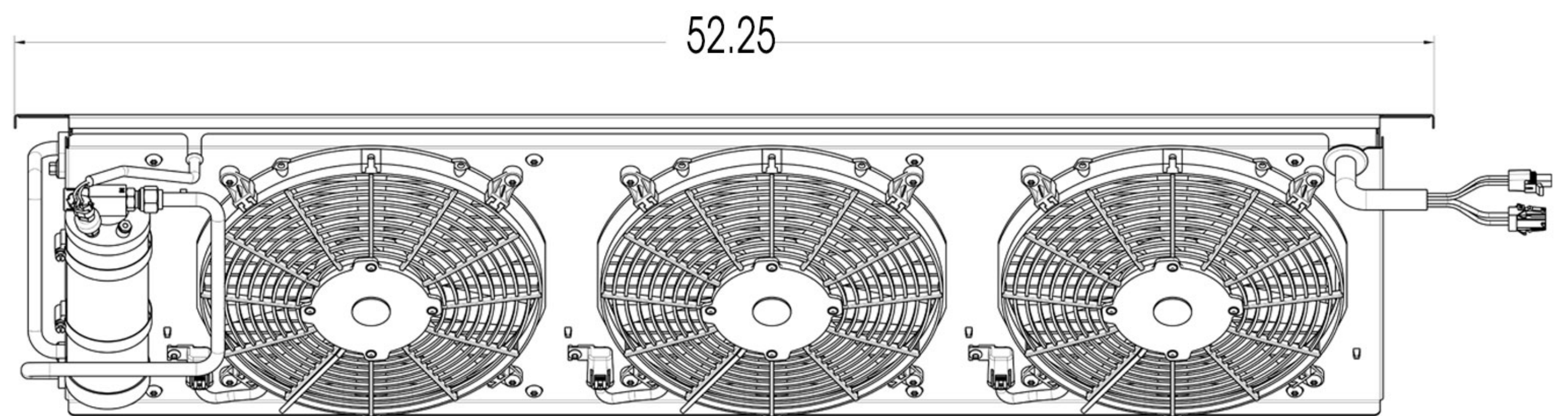

## DIRECT REPLACEMENT FOR MOST COMMON APPLICATIONS

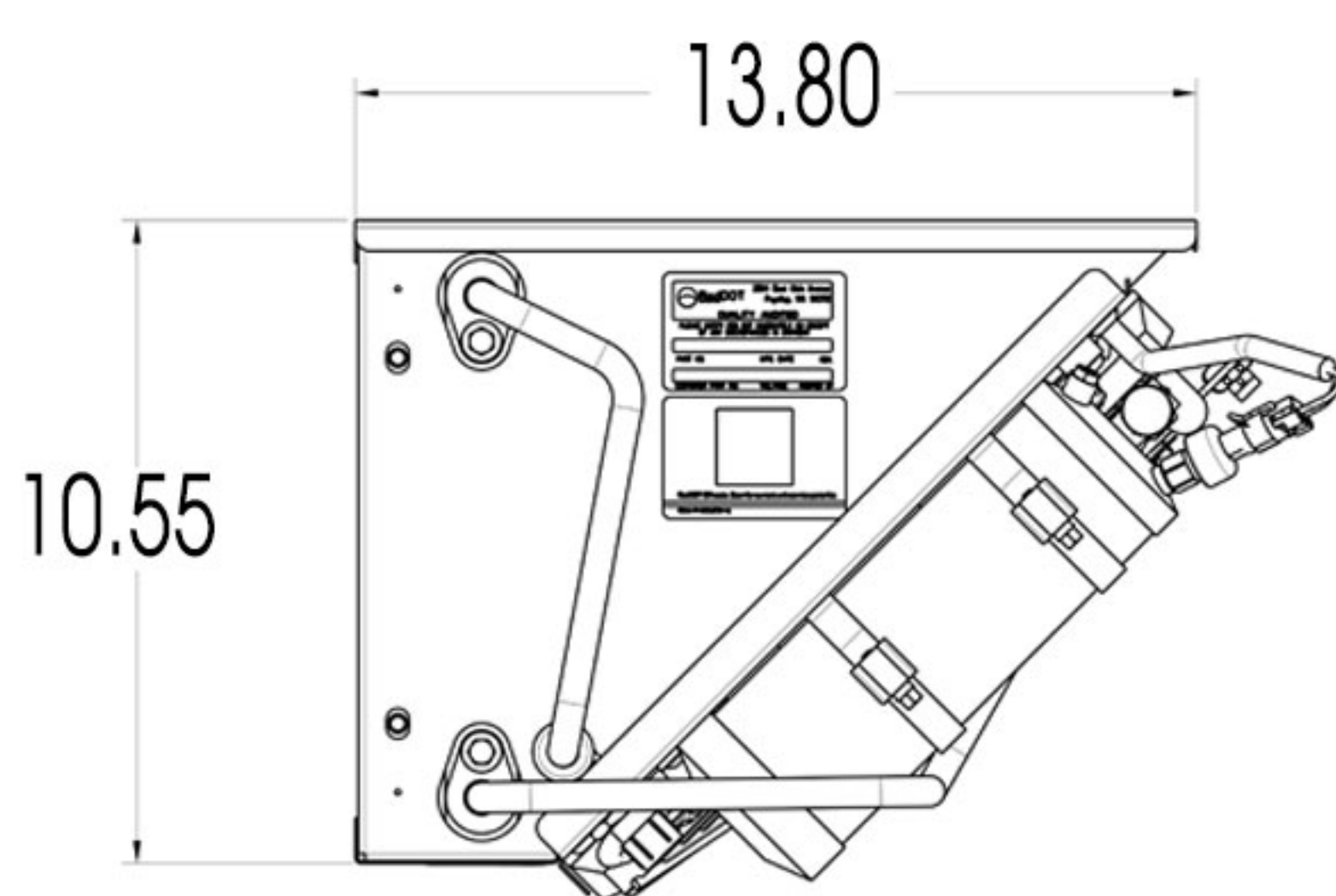

### SPECIFICATIONS

**CAPACITY:** 80,000 BTU/hr  
**WEIGHT:** 48lbs  
**AIR FLOW:** 2250 CFM  
**MOTORS:** 3 Spal 12" Fans  
**CURRENT DRAW:** 23 amps @ 13.6 VDC

### FEATURES

Micro Channel Condenser Coil  
Zinc Coated for Corrosion Protection  
Plug and Play Connectors  
Direct Bolt On Replacement